

### Description

Precision bimetallic- thermometer with rim-ring case. Execution axial according DIN EN 13190

### Accuracy

Class 1 according DIN EN 13190

### Temperature range

Scale ranges according to DIN EN 13190 see backpage  
(special scale ranges upon request)

### Case

Case with rim-ring stainless steel 1.4301 / AISI304  
Ingress protection IP 65 according to IEC 529  
Instrument glass window  
Nominal sizes 63, 80, 100, 125 mm

### Pointer and dial

Aluminium dial varnished white / black lettering  
Aluminium pointer varnished black

### Process connection

Revolving female nut  
Wetted parts of stainless steel 1.4571 / AISI316Ti

### Standard options

- Oil- fillings for damping (250 °C scale range max.)
- Maximum- and marking pointer

### Additional options (upon request)

- Safety glass or polycarbonate window
- Dual scales °C/°F, customer specific scales
- Special materials for wetted parts

## Suggestions for installation of thermometers with revolving gland nut

For further installation possibilities see chapter **protection tubes**

### Connector

for the installation in connections with internal threads

according to datasheet :

18.13

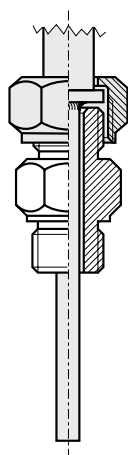

### Protection tube

screw-in type, fabricated

according to datasheet :

13.1  
13.0

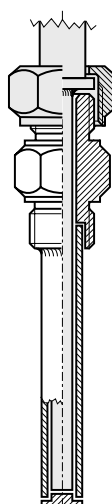

### Thread joint

screw-in type, solid drilled

according to datasheet :

13.1  
13.0

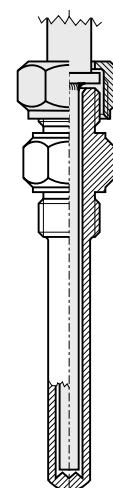

### Protection tube

weld-in type, solid drilled

according to datasheet :

11.0

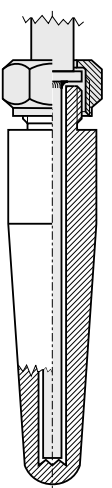

Revision 2.0 - 10/2004

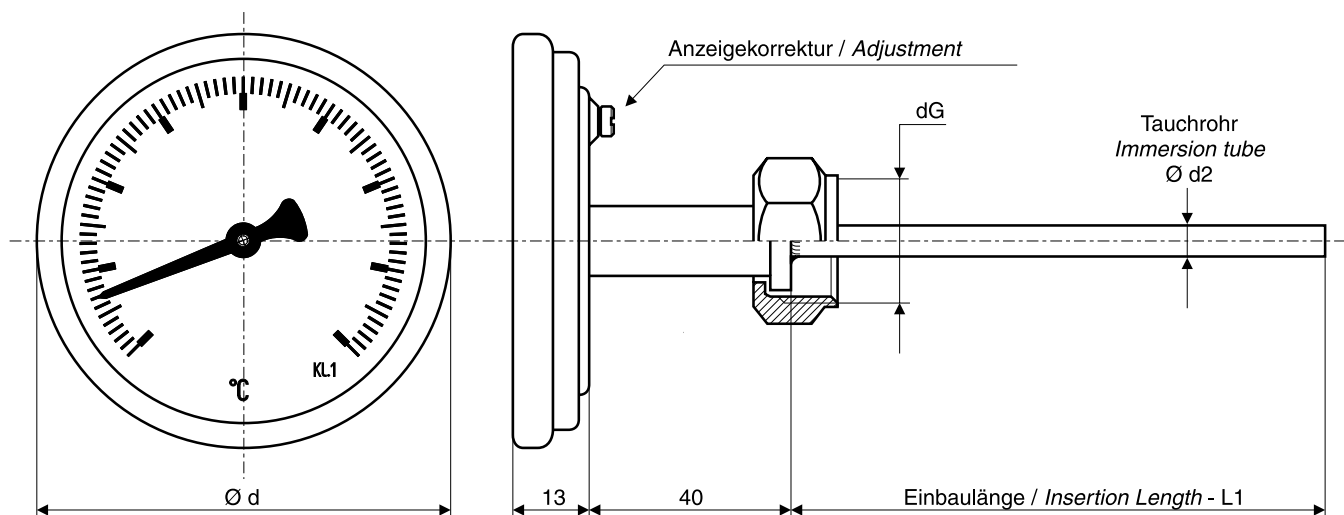

Case dimensions	
Ordering code	C
NG 63	3
NG 80	4
NG 100	5
NG 125	7

Thread	
Ordering code	N
G 1/2" 27 mm flats	1
G 3/4" 32 mm flats	2
G 1" 41 mm flats	3
M 18 x 1,5 24 mm flats	6
M 20 x 1,5 27 mm flats	7
M 24 x 1,5 32 mm flats	8
Special thread	9

Scale ranges	
Ordering code	F G
- 40 ... + 40 °C	4 9
- 40 ... + 60 °C	5 0
- 30 ... + 50 °C	5 2
- 20 ... + 40 °C	5 3
- 20 ... + 60 °C	5 4
0 ... + 60 °C	5 8
0 ... + 80 °C	5 9
0 ... + 100 °C	6 0
0 ... + 120 °C	6 1
0 ... + 160 °C	6 2
0 ... + 200 °C	6 3
0 ... + 250 °C	6 4
0 ... + 300 °C	6 5
0 ... + 350 °C	6 6
0 ... + 400 °C	6 7
0 ... + 500 °C	6 8
Special range	9 9

Additional equipment	
Ordering code	HI
Without	0 0
Marking pointer	5 0
Maximum pointer	6 0
Siliconeoil filled	7 0
Glycerinoil filled	8 0

### Ordering-code :

For ordering please fill out all empty digits in the order code on the right.

The code numbers for all free digits you find in the charts above.

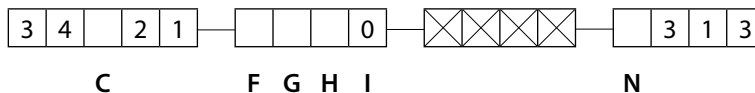

### For ordering please declare in plain text :

Ø Stem (d<sub>2</sub>) :                      Insertion length (L<sub>1</sub>):                      Special - range (upon request):                      Protectiontube acc. to datasheet:

6mm    8mm                      ..... mm                      .....°C to ..... °C                      .....

10mm