

Transmitter for Mounting Rails

for Thermocouples and Resistance thermometers

Datasheet 84.1

Transmitters

Description : Transmitter for the installation on mounting rails

Output : 4...20 mA two-wire technique
or 0...10 V three-wire technique

Load:
$$R_B = \frac{U_B - 6V}{20 \text{ mA}}$$

R_B = Load resistance
 U_B = Supply Voltage

Load Influence : (4...20 mA) 0,01 % / 100 Ω
(0...10 V) 0,1 % max

Current Limit : Max. current 35 mA

Response Time : $t_{90} < 1s$

Failure Signal : Current Output > 23 mA

Inputs : Platinum- RTD's acc. to DIN IEC 751
two- or three- wire technique
Thermocouples acc. to DIN IEC 584

Input RTD (Pt100) :

Smallest span : 40 K
Characteristic : temperature- linear
Accuracy : 0,2%
Temperature drift : 0,05% / 10K

Input Thermocouples :

Smallest span : 10 mV
Characteristic : voltage- linear
Accuracy : 0,1 % + 1,5 K
Temperature drift : 0,05 % / 10K
Temperature drift of cold junction compensation:
1 K / 10 K calibrated at 20°C
Thermocouple types :
NiCr - Ni (Type K) • Fe - CuNi (Type J)
Pt30%Rh - Pt6%Rh (Type B)
Pt10%Rh - Pt (Type S) ... others upon request

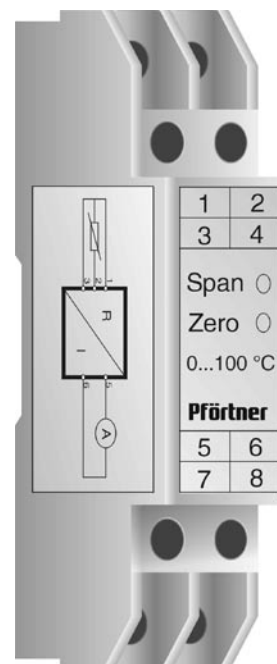

Supply Range : (4...20 mA) 6...32 V/DC
(0...10 V) 12...32 V/DC

Supply Influence : 0,05 % / 10 V

Ambient Temperature : - 25 ... + 75 °C

Housing: Plastic case for the installation on standard mounting rails according to EN 50022

Dimensions : 90 × 58 × 17,5 mm (B × H × T)

Protection class : IP 20 acc. to DIN 45 050

Clamps : Screw- clamps max. dia. 2,5 mm²

Transmitter for Mounting Rails

for Thermocouples and Resistance thermometers

Datasheet 84.1

Transmitters

Measuring ranges	
Ordering - code	F G
- 200 ... + 200 °C	4 1
- 200 ... + 50 °C	4 2
- 50 ... + 50 °C	4 9
0 ... + 60 °C	5 8
0 ... + 100 °C	6 0
0 ... + 200 °C	6 3
0 ... + 300 °C	6 5
0 ... + 400 °C	6 7
0 ... + 600 °C	6 9
0 ... + 800 °C	7 1
0 ... + 1200 °C	7 5
Special - range	9 9

Please declare special ranges in plain language - see bottom

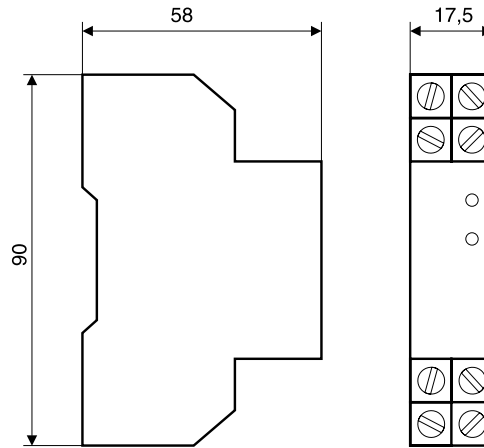

Connection diagram

Output : 4 ... 20 mA

0...10 V

Input	
Ordering - code	H I
Pt 100 DIN ISO	1 1
FeCu / Ni (J)	2 0
Ni / CrNi (K)	2 2
Pt Rh 10 / Pt (S)	2 5
Pt Rh 30 / Pt 6 (B)	2 7

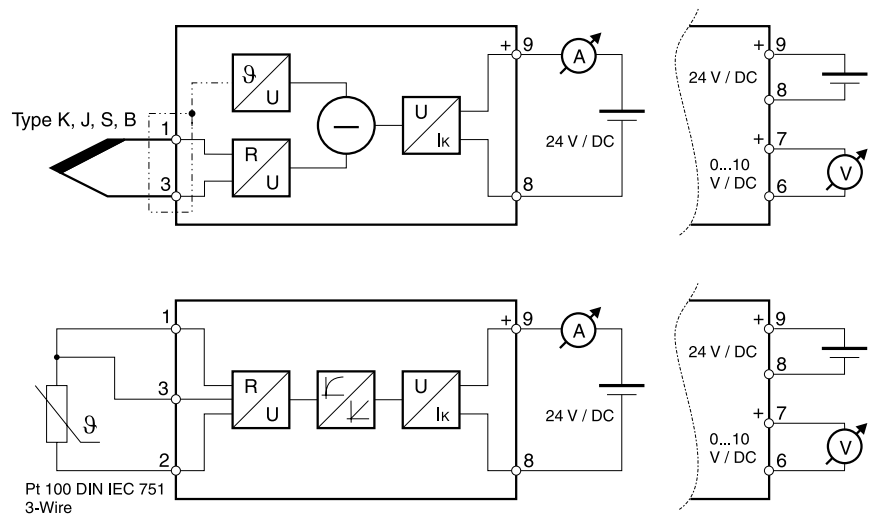

Output	
Ordering - code	L M
4 ... 20 mA	0 2
0 ... 10 V	0 3
others upon request	

Ordering-code :

for ordering please fill out all empty digits in the order code on the right.

The code numbers for all free digits you find in the charts above.

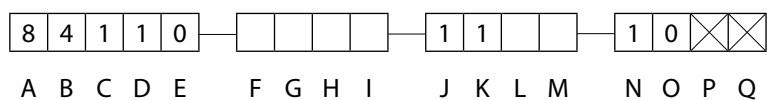

For ordering please declare in plain language :

Range (notice the minimum spans on page 1)

..... °C to °C correspond to the output signal range